



SPARTAN FLOOD IR24



LED Hazardous Area Floodlight Standard and Emergency Variants

The SPARTAN Floodlight range is designed specifically for hazardous environments which require high performance, high reliability, Infra-Red illumination. Available in both standard and emergency versions and using Raytec's field-proven, long-life LED technology, SPARTAN Floodlights are ATEX and IEC Ex approved for all Zone 1 and Zone 2 applications and rated for T4, T5 and T6 environments.

SPARTAN Flood has been designed with maintenance in mind. A unique modular design allows key components to be easily accessed and serviced if required, making inspection and maintenance quicker and easier. It also allows for the most flexible installation. The PSU chassis can be removed and located remotely at ground level for areas with difficult access, while standard units can also be upgraded to an emergency fitting at any time with an additional battery back-up module.

SPARTAN Flood is available in a variety of different beam patterns, both circular and elliptical, with revolutionary interchangeable VARIO lens inserts which can be easily altered on-site delivering the ultimate flexibility to specifiers, distributors and end-users.

SPARTAN uses **COOLEXTRUDE™** thermal management technology, ensuring a much cooler LED operating temperature and up to 60% better heat dissipation compared to traditional lighting solutions, allowing the product to operate for > 10 years while still delivering high performance Infra-Red illumination

Features

- ATEX & IEC EX approved - Zone 1 & 2
UL/CSA approved including C1D2
- Ultra long life LED
- Easy installation, maintenance and inspection
- Emergency variants
- Wide operating temperature range of -50° to +55°C
- Integral photocell (optional)
- VARIO lens technology – easy modification of beam patterns
- 5 year warranty

Why Raytec

- UK Designed & Manufactured
- Manufacturing precision engineered LED products
- Worldwide distributor support
- Lighting design and full technical support
- ISO9001 and ISO140001 accredited
- Award Winning Technology

Extended Features

Ultra-Powerful

Latest high power LED technology

Ultra-Flexible

Beam patterns from 10° to 120° both circular and elliptical.

Operating temperature range of -50°C to + 55°C with a T4/T5/T6 rating for even the most challenging conditions. (-20°C emergency variants)

Models incorporating VARIO Technology allow for easy modification of beam pattern.

Ultra-Reliable

Industry leading 5 year warranty

Designed and manufactured in the UK to the highest standards including both ISO9001 & ISO14001.

Advanced electronics and LED's protected by vibration resistant and water proof potting compound

Ultra-Modular

Both the LED and PSU modules are easily accessible for maintenance and inspection

Available as a standard or emergency fitting – upgradeable on site.

Removable PSU housing allows power supply to be fitted remotely

Ultra-Efficient

COOLEXTRUDE™ thermal management delivers class leading energy efficiency

Significant running and maintenance savings compared to traditional lighting technologies

SMART access wiring system for safe and efficient installation, set-up and ongoing inspection

Ultra-Support

Photometric files available (.ies & .ldt)

Full Lighting Design Service

Site specific Energy and Cost Saving Report available

Product Dimensions

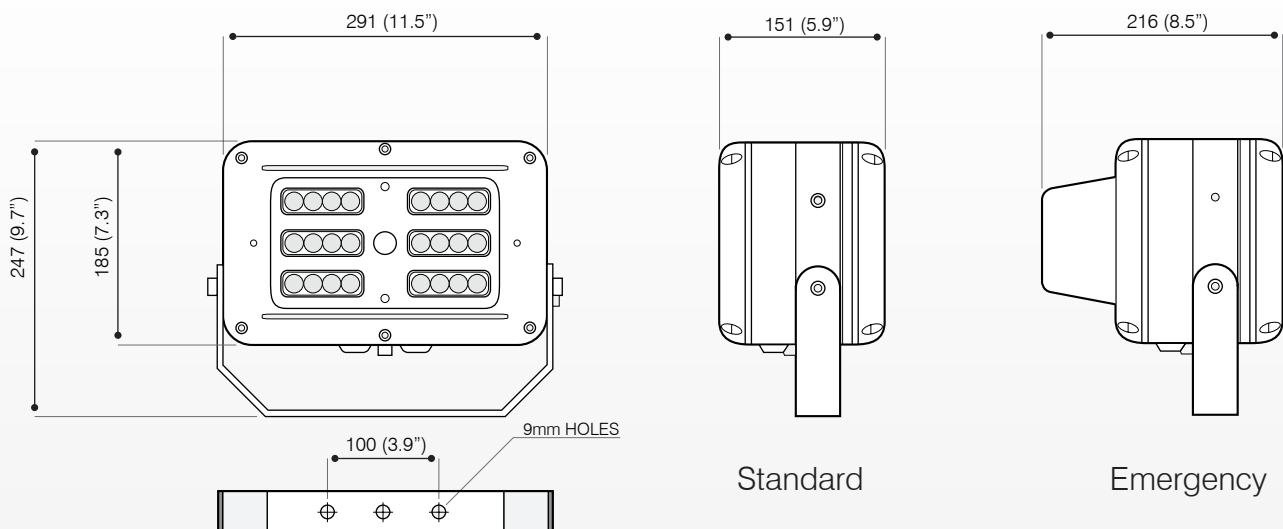

Technical Specifications

Certification

ATEX Rating:	ATEX and IEC Ex rated for Gas and Dust
Hazardous Area rating:	Zone 1 & 2 – Gas and Dust
Certificates:	CML13ATEX3007 & IEC Ex CML 14.0001 UL/CSA, including C1D2
Gas:	II 2 GD Ex emb IIC T5 or T4 Gb Ta -50°C to +55°C (-20°C emergency variants) II 2 GD Ex emb IIC T6 Gb Ta -50°C to +48°C (-20°C emergency variants)
Dust:	Ex tb IIIC T82°C Db IP66 & IP67 - Ta -50°C to +55°C (-20°C emergency variants)

Electrical

Input:	110-254V 50/60Hz AC only Low voltage option also available for standard variants only - 18-30V AC/DC
Power:	68W standard, 70W emergency
Termination:	Incoming terminal block suitable for looping 4 core 4mm ² cable
Power Factor	>0.95
Cable entries	2xM20 as standard (other entries available upon request), dispatched complete with one ATEX/IEC Ex approved blanking plug

Optical

Beam Patterns-circular:	10°x 10° or 30°x 30° or 50°x 50° or 120°x 120° (10 x 10 option can be upgraded to VARIO Technology)
Beam Patterns-elliptical:	35°x 10° or 60°x 25° or 80°x 30° or 120°x 50° (VARIO)
LED type:	Platinum Elite SMT LEDs
Number of LEDs:	24

Mechanical/Environmental

Burning position:	Universal
IP rating:	IP66 & IP67
Temperature range:	-50°C to +55°C (-20°C emergency variants)
Weight:	8kg (17.6lbs) Standard, 10Kg (22lbs) Emergency
Enclosure:	Marine grade aluminium epoxy powder coated, toughened glass, all external fasteners and brackets are marine grade stainless steel
Unit Colour:	Silver (RAL 9006) Red (RAL3024) - Emergency cover
Installation instructions:	Raytec ref 910-M-0094 – please contact Raytec for copy
Dimensions:	Standard - 291 x 247 x 150 (11.5 x 9.7 x 6") Emergency - 291 x 247 x 215mm (11.5 x 9.7 x 8.5")
Mounting:	U bracket (see dimension drawings on Page 2) – complete with locking screw

Emergency

Duration:	Up to 2hrs at 50% power Other options available
Battery:	Ni/Cd 12V 4.5Ah
Charge time:	20 hours

Circular beam pattern

Part Codes	Description (T4 variants as standard)	Distances
SPX-FL24-I-1010	SPARTAN Flood, 24 LED, Infra-Red, 10°x 10° beam	325m
SPX-FL24-I-3030	SPARTAN Flood, 24 LED, Infra-Red, 30°x 30° beam	99m
SPX-FL24-I-5050	SPARTAN Flood, 24 LED, Infra-Red, 50°x 50° beam	80m
SPX-FL24-I-120120	SPARTAN Flood, 24 LED, Infra-Red, 120°x 120° beam	32m

For emergency versions – add '-EM' to the above codes
For options fitted with photocell add '-PC' to the above codes
For low voltage versions add '-LV' to the above codes
Contact Raytec for T5 and T6 variants

Elliptical beam pattern

Part Codes	Description (T4 variants as standard)	Distances
SPX-FL24-I-3510	Spartan Flood, 24 LED, Infra-Red, 35°x 10° beam	158m
SPX-FL24-I-6025	Spartan Flood, 24 LED, Infra-Red, 60°x 25° beam	113m
SPX-FL24-I-8030	Spartan Flood, 24 LED, Infra-Red, 80°x 30° beam	73m
SPX-FL24-I-12050	Spartan Flood, 24 LED, Infra-Red, 120°x 50° beam	49m

For emergency versions – add '-EM' to the above codes
For options fitted with photocell add '-PC' to the above codes
For low voltage versions add '-LV' to the above codes
Contact Raytec for T5 and T6 variants



Beam patterns - Circular

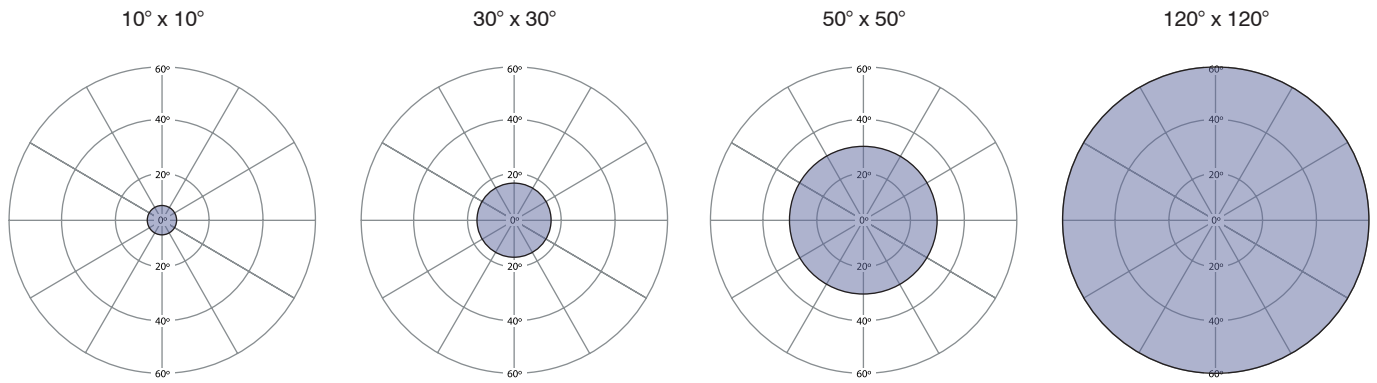

Beam patterns – Elliptical (VARIO)

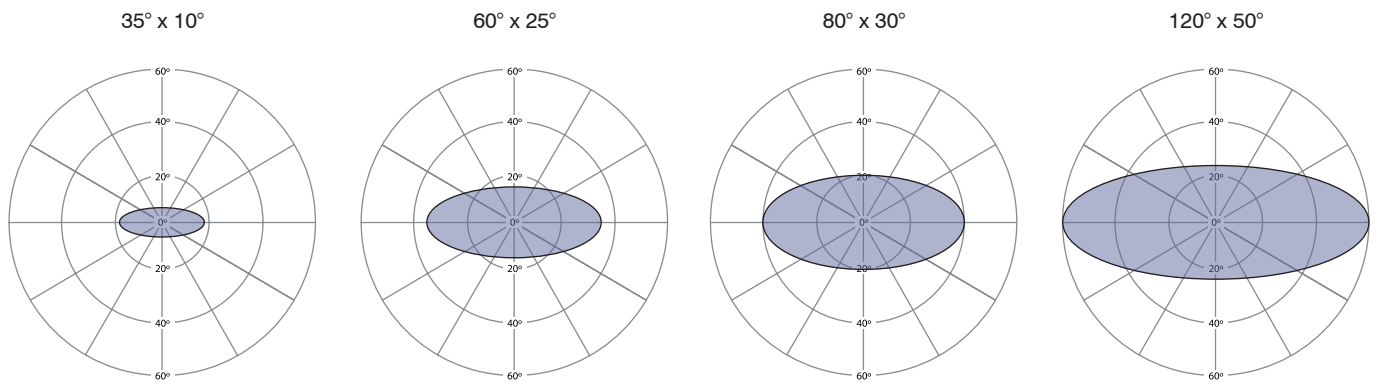

Products in the Spartan Flood 24 range

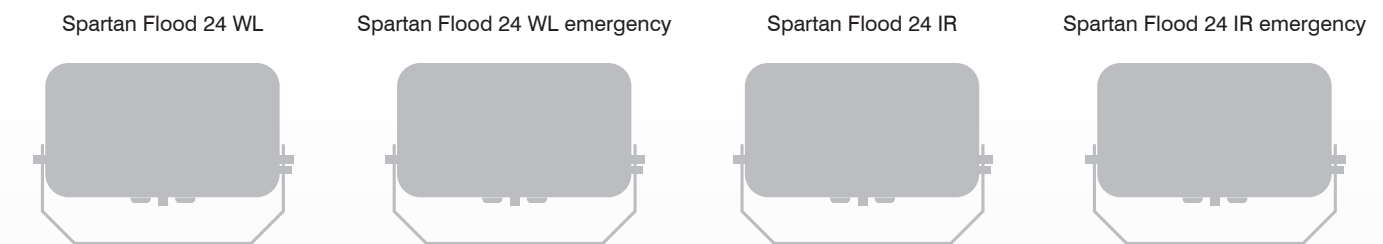

Other Products in the Spartan Hazardous Area Family

